

GC28 Three Way Drop-T Non-Locking Latch System

Features

- Complete latching system for the largest doors. Handle, latch and flush recess pan form a self contained unit needing only a simple cut-out.
- Rods attached on site and adjustable for either LR or RH movement
- Polished die cast 'hub', and neoprene seal under stainless 'cup' washer for good appearance, corrosion-resistance and weatherproofing
- Lift handle to turn, releasing latch tongue and withdrawing rods.
- Reverse to close. Tongue has 5 mm cam-form for easy engagement
- Latch travels 90° from centre against 'stops', which can be adjusted to allow either LH or RH operation.
- Four holes in flanges at 7.5 mm diameter. Rods are secured by split pins through pillar rivets.

Material

- 'T' pan: Stainless steel 304, bright polished, or mild steel to CR4, zinc-plated
- 'T' handle and hub: Zinc die cast, polished and chromium plated or zinc-plated



GC28-G01563

- Complete system, supplied with rods and guides
- Assembled and 'handed' on site
- Stainless steel or zinc-plated

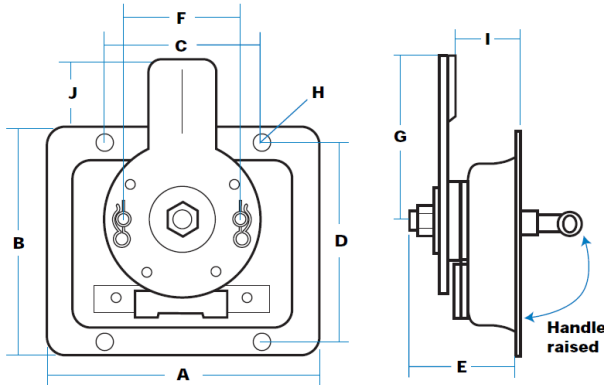

Direction of Movement

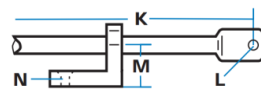
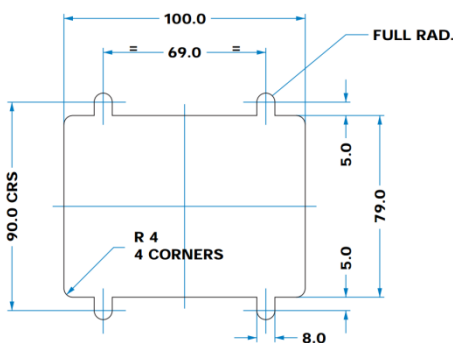
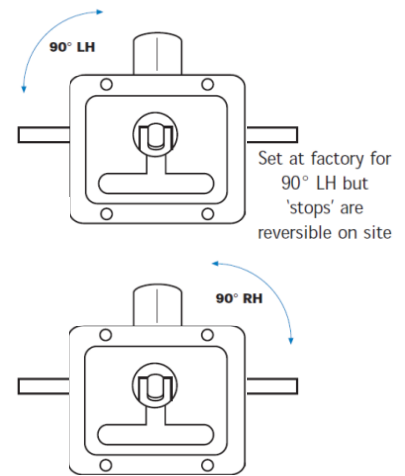

K	Rod length	1145 x 9.5 mm
L	Hole dimension (dia.)	7.5 mm
M	Height to central line	14 mm
N	Hole sizes (dia.)	5 mm c/s 10 mm

Rods withdraw by 25mm in line of travel, as latch disc rotates through 90°.

Rod Ref (G18702), Guides Ref (G18716)

Part No.	Type	Material	A	B	C	D	E	F	G	H	I	J
GC28-G01563	Complete System	Stainless Steel	120	125	69	90	45	52	Length of latch: 70 Cam depth: 3	7.5	27	30
GC28-G01564		Mild Steel										
GC28-G01569	Centre Case Only	Stainless Steel										
GC28-G01570		Mild Steel										

Options & Add-Ons

Tongues have 3mm cam-form

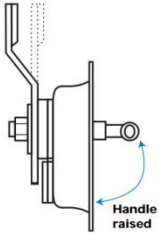

'Cranked down'
3-way tongue can be shaped to increase 'L' dimensions
Suffix A
L=32mm
Suffix B
L=37mm

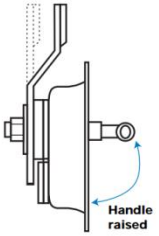

'Cranked up'
3-way tongue can be shaped to reduce 'L' dimensions
Suffix C
L=22mm
Suffix D
L=17mm

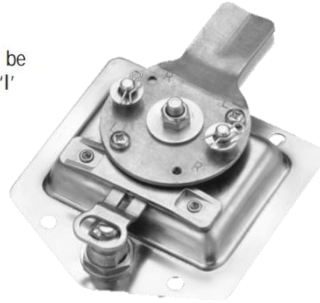

Illustration shows 3-way centre with tongue cranked down to 37 mm. Also visible are pillar-rivets for attachment of rods, and screws to set 'L' or 'R' movement

LATCH TONGUE OPTIONS

The standard multi-point latch tongue can be cranked to give a number of options, providing engagement depths between 17 - 37 mm in 5 mm increments. However this is not adjustable and cannot be varied on site.

Use the suffix letters shown to specify the cam pawl required.

STUD FIXING

This is an optional feature which allows the 'Drop-T' unit to be secured from beneath, with no mounting holes, screws or rivets visible from outside.

Four weld-studs (M6 x 15 mm) are fitted to the flanges in same positions as normal mounting holes, giving better appearance, more security, and preventing entry of corrosion-causing agents.

Stud-fixing is an option on all 'Drop-T' models, including mild steel and powder coated versions.

To order, add the suffix "-SF" to our regular part numbers.



GC23-G01501-SF
(Drop-T with stud-fixing, also showing rubber gasket and die cast support bracket)



WEATHERSHIELD LOCKS

Where additional protection is desired for the lock cylinder, the 'Drop-T' can be fitted with a protective cover. Two styles are available, either a sliding die cast plate (chrome) or a moulded flip-up cap as illustrated. They can be used with all 'Drop-T' models.

To order, add the suffix "-MC" or "-WS" respectively to our regular part numbers.



'Drop-T' with flip-up moulded cap (G00928)



'Drop-T' with sliding weathershield cover, using lock (G08996)